

Residential Refrigerator Guide

This guide is intended to assist Heartland Owners in understanding how to operate and troubleshoot their residential refrigerator. It is intended to supplement the information in the manufacturer's manual.

Important Notices

Who created this document?

This document has been created by Heartland Owners independently of the Heartland RV Company, and is posted to the Heartland Owners Forum as a service to the owner community.

Errors and Omissions

Because the authors are Heartland owners, not engineers or service technicians, it's possible that this document could contain errors or omissions. Readers are advised to also review the manufacturers' product documentation for more complete information and guidance.

Limitations on Using this Document

- This document may not be modified or sold.
- It may not be posted on the internet without permission.
- Other websites may link to the page from which the document may be downloaded, but may not link directly to the document without permission (search engines excluded).

Contact Information

Questions and comments may be directed to manuals@heartlandowners.org

Residential Refrigerator Guide

Table of Contents

Introduction	3
Basic Operation.....	3
Battery Life.....	3
Start Up.....	3
Before Traveling.....	4
Turning the Refrigerator OFF When Storing the RV	4
Other Refrigerator Usage Instructions.....	4
Winterizing and De-Winterizing the Residential Refrigerator	4
Three Possible Methods of Winterizing.....	4
Using the Drain Valve.....	5
Antifreeze Method.....	5
Using Compressed Air to Winterize the Refrigerator	5
De-winterizing the Refrigerator After Using Compressed Air to Winterize	8
Troubleshooting Power Issues.....	9
Physical Layout of Electrical Components	9
Revision History	12

Residential Refrigerator Guide

Introduction

The 22 cubic foot residential refrigerator option provides owners with a refrigerator such as you would have in your “sticks and bricks home” that holds its temperature better than the traditional (absorption) RV refrigerator and is larger than traditional RV refrigerators. The option consists of an electric only (110V AC) refrigerator with water dispenser and ice maker, along with additional electrical components to supply 110V to the refrigerator when the RV is not plugged into shore power.

With the residential refrigerator option, Heartland includes an extra 12V battery, a dedicated power inverter that converts 12V DC into 110V AC, and an automatic transfer switch that switches to the inverter output when shore power is disconnected. There is also a remote switch that allows you to turn the power inverter ON or OFF.

This arrangement allows you to unplug shore power when you leave home or campsite, and keep the refrigerator running as you travel to your next destination.

Basic Operation

This manual is intended to supplement the manufacturer’s refrigerator manual, so the explanations here will focus on the additional components and on usage aspects that are related to RV’ing.

Battery Life

The 2 supplied batteries are tied together in parallel. As long as your batteries start the day with a full charge and are in good condition, there should be plenty of power to run the refrigerator while traveling an entire day. The batteries might supply enough power to run the refrigerator overnight as well, if you aren’t using too much battery power for other devices.

Be aware that in sub-freezing weather where the furnace would be running a good bit of the night, the total usage of all 12V devices could exceed the capability of your batteries.

Unless you have supplemental power from a solar array or a generator, the residential refrigerator option is probably not a good choice if you plan on frequently camping more than one night in locations that do not provide electrical hookups.

Start Up

When you get your RV out of storage and are loading up and preparing for a trip, you’ll need to plug into 110V to get the refrigerator cooled down, before putting food into it. You’ll also need to turn the refrigerator ON.

As with any home refrigerator, you may need to allow between 12 and 24 hours for it to reach optimum temperature.

Before Traveling

NOTE: You must turn the power inverter ON before you begin travel or the refrigerator will not receive power after shore power is disconnected.

Each time 12V DC power is applied to the coach either by plugging into shore power, or by turning the inverter's battery cutoff switch to ON, the inverter that is dedicated to the refrigerator starts in an OFF condition. You must turn the inverter ON either by pressing the local switch on the inverter box, or by using the remote switch that is located either inside the coach, or in the front storage area. The remote switch panel has a light that indicates when the inverter is ON.

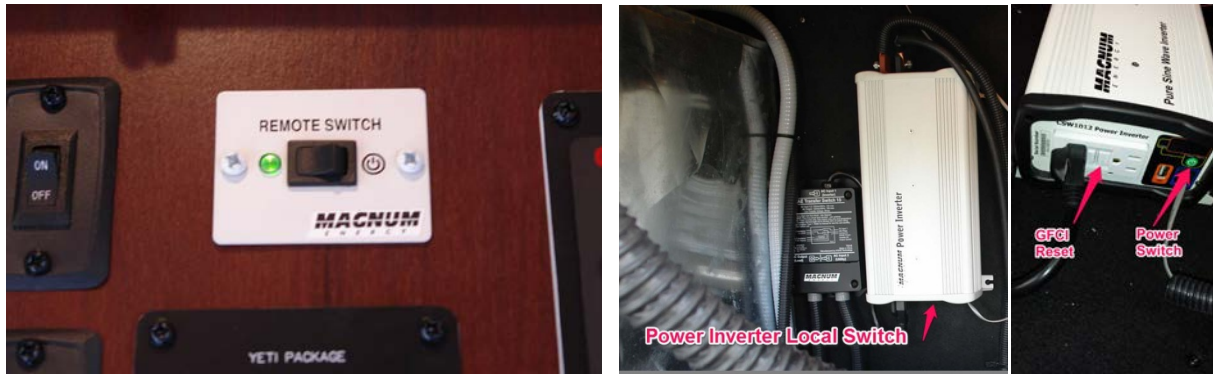

Turning the Refrigerator OFF When Storing the RV

The manufacturer's manual says to press and hold the ON/OFF button for 3 seconds to turn the refrigerator OFF. However, they also note that this does not turn off the interior light and circuit boards. This will create a parasitic drain on your batteries while in storage unless you turn the power inverter OFF or use the inverter's dedicated battery power cutoff switch to cut power to the inverter.

NOTE: To prevent parasitic drain of the batteries when not plugged into shore power, or when in storage, you must turn the power inverter OFF or use the inverter's dedicated battery power cutoff switch (if so equipped) to shut the refrigerator completely OFF.

Other Refrigerator Usage Instructions

Please refer to the manufacturer's manual for general instructions on how to use and care for the refrigerator. If you cannot locate the copy that came with your trailer, check the [manuals section of the Heartland Owners Forum](#).

Winterizing and De-Winterizing the Residential Refrigerator

Three Possible Methods of Winterizing

To avoid freeze damage, all water needs to be evacuated from a number of areas including the 1/4" supply line to the refrigerator, the reservoir coil inside the refrigerator, the ice maker and water dispenser lines inside the refrigerator, the ice maker and water dispenser solenoids inside the refrigerator, and the drain valve under the slide out (if so equipped).

While winterizing is usually thought of as something that is needed when storing the RV for the winter, you must also protect the exterior portion of the water supply line when the RV is in use and temperatures are projected to drop below freezing.

CAUTION: A portion of the water supply line to the refrigerator runs underneath the slide out and is exposed to outside air. If temperatures go below freezing, the line will quickly freeze and will be damaged even if you keep the inside of the coach at a comfortable temperature. Because the water in the line is not heated, insulating the exposed line will only prevent freeze damage for a very short time in sub-freezing temperatures.

You ***must*** evacuate water from the supply line to protect from freeze damage.

Using the Drain Valve

Starting with early builds of the Residential Refrigerator option, a drain valve was installed on the trailer frame, underneath the refrigerator. By opening this drain, you can evacuate some of the water from the refrigerator. However, there is approximately 1 quart (1 liter) of water inside the refrigerator and some components may retain water even if you are successful in draining about a quart.

Antifreeze Method

While using RV antifreeze will protect the components from freeze damage, there could be issues with taste of the water and ice. With PEX water lines, antifreeze flushes out and taste usually returns to normal very quickly after de-winterizing. However, the 1/4" water supply line is a different material. Some owners have found that the supply line, solenoids, and reservoir may retain the taste of antifreeze for a longer time.

Also, if using antifreeze, when the antifreeze comes out the ice maker feed line, it will make a mess in the freezer compartment.

Due to these possible issues, we do not recommend RV antifreeze for the refrigerator.

Because it's the most thorough and cleanest method, we do recommend using compressed air.

Using Compressed Air to Winterize the Refrigerator

Using compressed air at 40 psi or less to evacuate water from the ice maker and water dispenser and related components is the safest, most thorough and cleanest method available. The downside of course is that you'll need an air compressor and appropriate connectors to use this method.

NOTE: If using RV antifreeze to protect the rest of the water system, the refrigerator procedure should be completed first, before introducing antifreeze into the RV's other water lines.

1. Locate the cutoff valve for the 1/4" ice maker and water dispenser supply line. It's usually under the kitchen sink. Another possible location is behind the water connections in the Universal Docking Center (UDC). If located behind the UDC, you may have to remove the rear wall of the area.

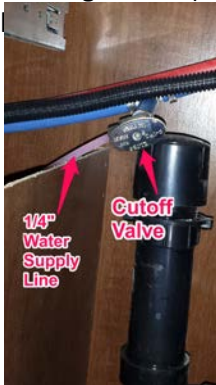

2. Locate the outside supply line drain valve under the slide out near where the refrigerator is located (if so equipped).

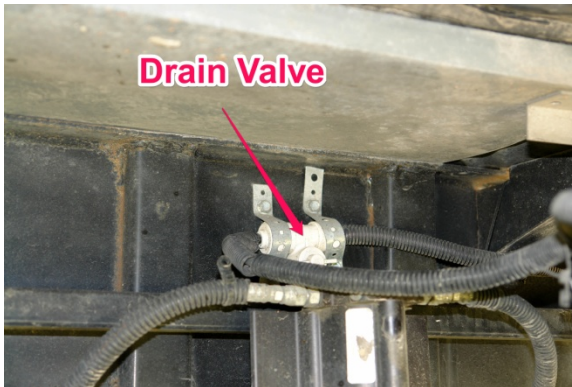

3. Using a water hose blowout plug on the end of your air compressor air hose, connect the compressor to the city water inlet and set the 4-way Anderson Valve to the City Water position. (The Anderson Valve pictured below is shown for reference, but as pictured, is not in the City Water position.)

The blowout plug pictured below is a Camco 36143 Blow Out Plug with Brass Quick Connect. It can be obtained from many dealer parts departments or from online stores such as Amazon.com, Tweetys.com or others.



4. Set the compressor to 40 psi or less and turn it on. If no faucets are open, the compressor should reach 40 psi in a few seconds and stop running.
5. Use a 2 quart bowl to collect water from the water dispenser. Hold the bowl against the dispenser to allow air pressure to force water through the supply line and reservoir coil and on into the bowl. Do not operate the dispenser for longer than a minute without allowing the solenoid to rest and cool down for a minute or two.



6. You should expect approximately 1 quart (or 1 liter) of water. After a steady stream of water stops, let the dispenser spit for another minute.
7. Open the freezer compartment and lift off the ice cream cover from over the ice maker, if removable. If it's screwed in place, either remove the mounting screws, or instead remove the ice tray and reach behind the ice cream cover to operate the ice maker power switch.

Use the ice maker power switch to manually start an ice harvest cycle by pressing the | indicator on the switch and holding it down for about 15 seconds. The bail arm should begin to move, indicating that the harvest cycle has started. Once the bail arm moves, you may release the switch.



8. After the bail arm returns to its normal rest position, wait another 60 seconds. The ice maker solenoid will activate and a little remaining water will be sprayed out to the front along with compressed air.
9. Run at least one more manual cycle of the ice maker. When all that's released is a fine mist of water, the lines are fully evacuated.
10. Use the switch on the front of the ice maker to turn the ice maker OFF. This will keep it from trying to run when power is applied to the refrigerator, perhaps before you de-winterize.
11. Replace the ice maker ice cream cover if removed, and replace the ice tray if removed.

12. Remove the water filter. At this point the feed lines to the water dispenser and ice maker are disabled.



If putting the RV into storage for the winter, you should purchase a replacement filter and discard the old one. If left in the RV in cold weather the remaining water in the old filter could freeze and damage the filter. Most manufacturers recommend changing filters every 6 months, so this is a good time to prepare for a new filter. BUT, do not install the new filter until you are done de-winterizing.

13. Locate the outside supply line drain valve (if so equipped) under the slide out and open it to allow compressed air to evacuate any traces of water from the valve assembly. There should not be more than a few drops.
14. Close the valve.
15. Locate the cutoff valve for the supply line and close the supply line.
16. Shut off the compressor and disconnect the air lines.

De-winterizing the Refrigerator After Using Compressed Air to Winterize

NOTE: Do not de-winterize the refrigerator until AFTER you de-winterize the rest of the water system. If you used RV antifreeze, be sure to flush the water lines sufficiently that you don't introduce residual amounts of antifreeze into the refrigerator.

1. Check that the exterior supply line valve is closed (if so equipped).
2. Open the cutoff valve for the supply line.
3. Insert the new water filter.
4. Using a large bowl to catch the water, press it against the water dispenser lever. After a few seconds, water and air will begin to spit out into the bowl. This will be followed by a solid stream of water.
5. Follow the filter manufacturer's recommendations for running water through a new filter to remove loose particulates.
6. Lift off the ice cream shelf from over the ice maker, removing screws if necessary.
7. Turn the ice maker switch ON.
8. Hold the switch in the | position for 15 seconds to start a manual harvest cycle. After the bail returns to the normal rest position wait 60 seconds for the solenoid to activate allowing air and water to flow.
9. Run several harvest cycles manually until a solid stream of water is observed when the solenoid activates.
10. Clean any spilled water out of the ice maker basket and replace the cover.

Troubleshooting Power Issues

WARNING: Troubleshooting power problems may require probing in areas where hazardous electrical current is present. If you are not familiar or comfortable with working around electrical circuits, you should get assistance from a qualified technician.

Before starting to use the diagnostic flowchart on the next page, check:

- The coach is plugged in to 110V shore power
- All circuit breakers are on. None are tripped. If not sure, turn each OFF and ON
- The batteries are charged
- The battery and inverter cutoff switches are turned ON.

You are troubleshooting because the refrigerator will not turn ON, or when shore power is removed, the refrigerator loses power and all refrigerator control panel lights go out.

If you are having other problems, such as a cooling problem, you should consult your dealer or a qualified refrigerator repair technician.

Physical Layout of Electrical Components

Position of major electrical components providing power to the refrigerator may vary, but will contain the components pictured below. Interconnections are shown on the block diagram that follows.

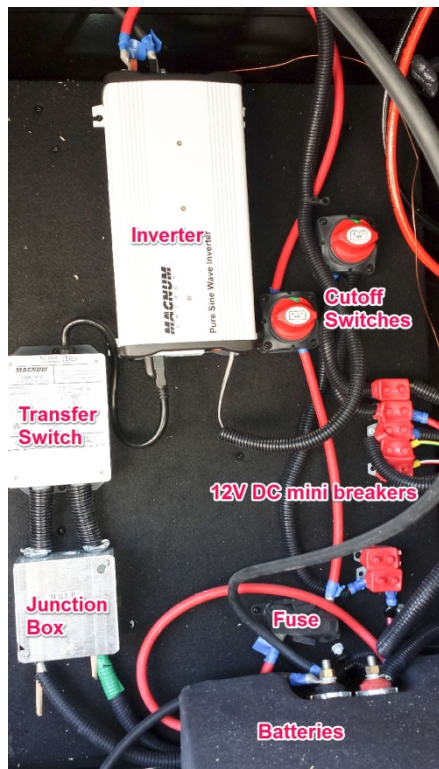

Residential Refrigerator Power Troubleshooting Flowchart

Before starting to use this flowchart, check:

- The coach is plugged in to 110V shore power
- All circuit breakers are on. None are tripped. If not sure, turn each OFF and ON
- The batteries are charged
- The battery and inverter cutoff switches are turned ON.

You are troubleshooting because the refrigerator will not turn ON, or when shore power is removed, the refrigerator loses power and all refrigerator control panel lights go out.

If you are having other problems, such as a cooling problem, you should consult your dealer or a qualified refrigerator repair technician.

START HERE

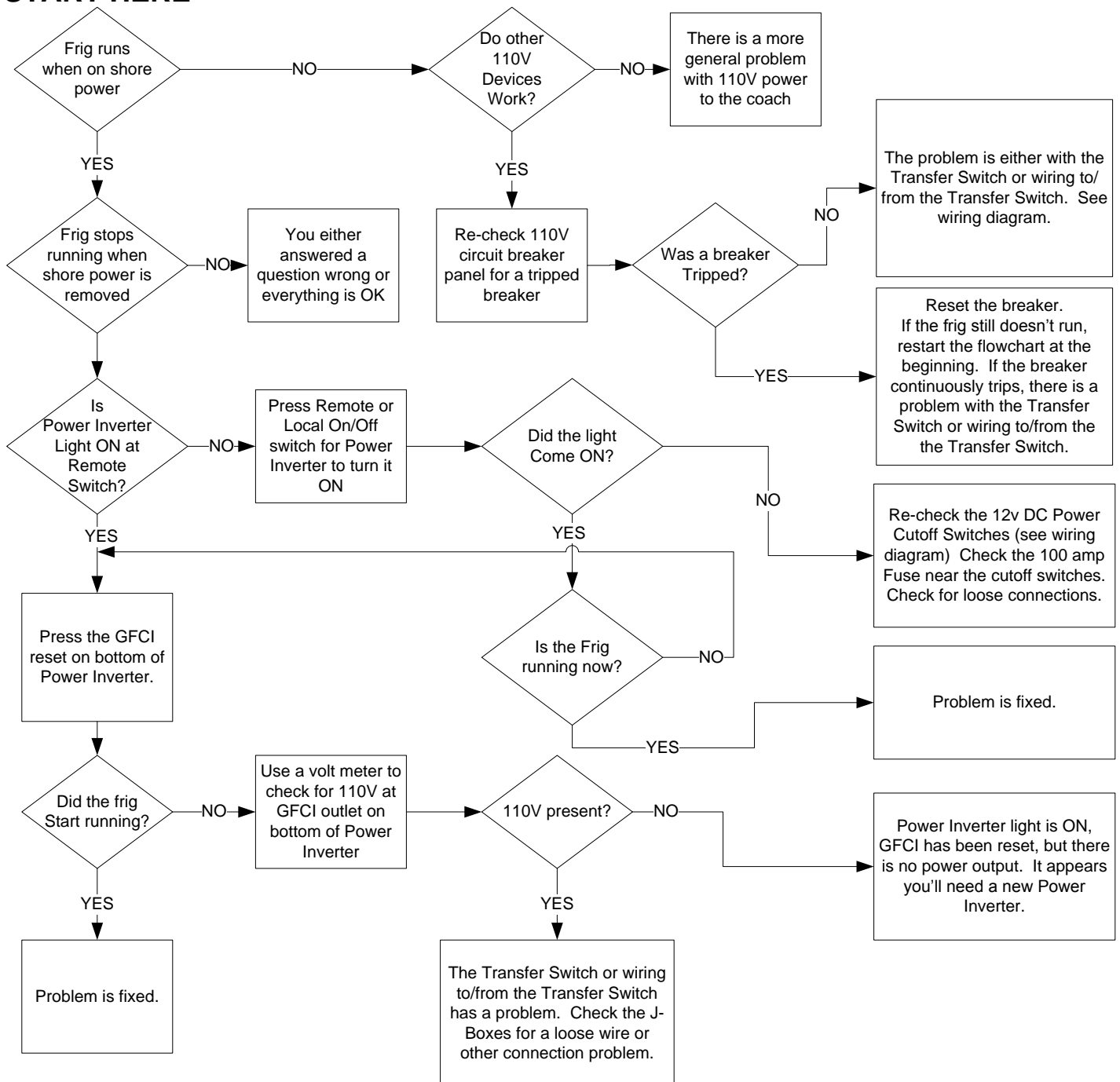

Block Diagram of Residential Refrigerator Electrical Wiring 4/23/2014

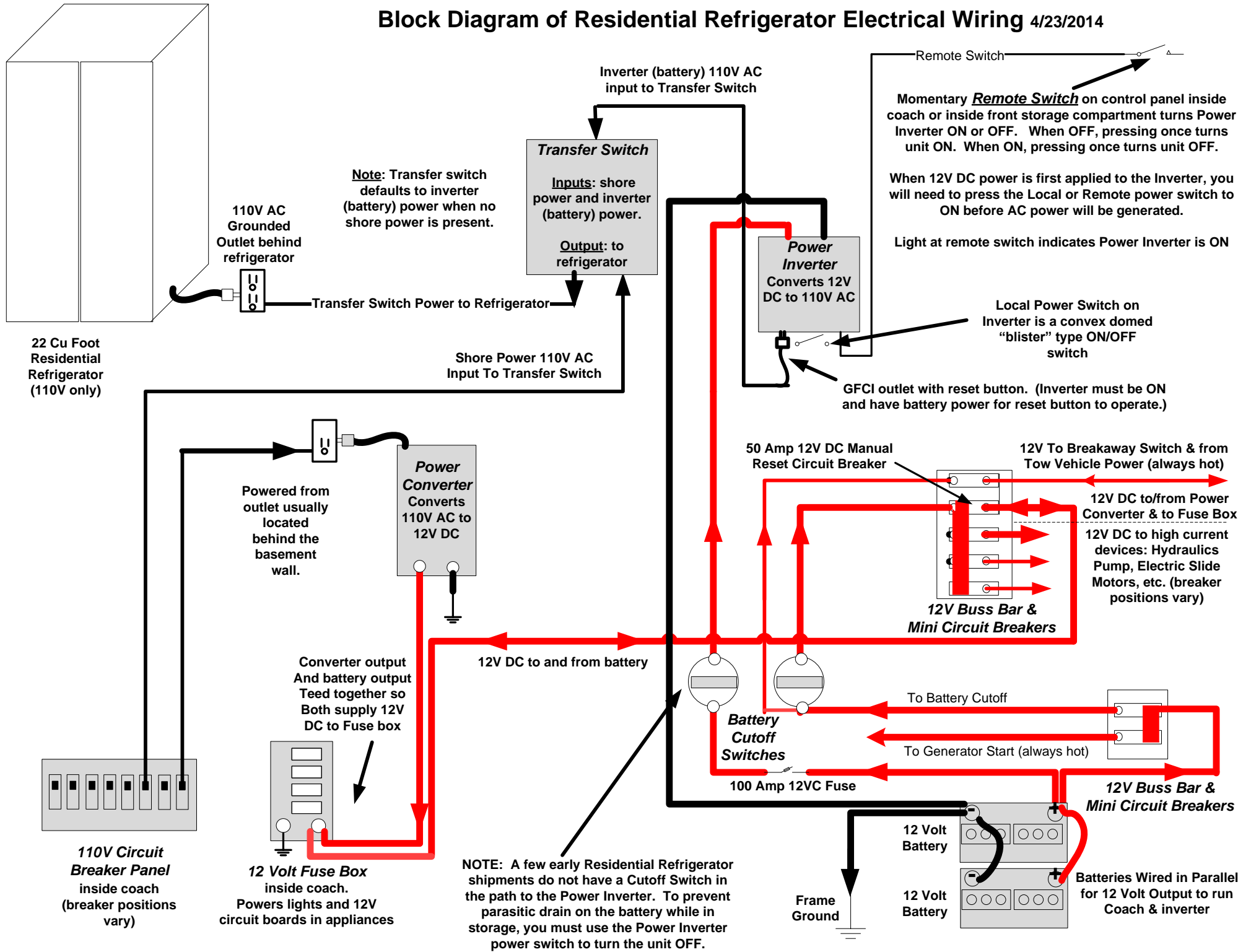

Revision History

April 23, 2014

Version 1.0 released